



Al Elast contact disc

Contact element for reliable connection of flat busbars.

Al Elast contact disc:

Reliable connection for Al and Cu busbars

There are risks involved in forming an electrical contact between flat metal surfaces: high current density at the actual contact points, and contact corrosion. Both impede current flow, and in the long term can cause the electrical connection to fail. Al Elast contact discs prevent these effects and enable reliable, ageing-resistant bolted connections between flat contact surfaces made of aluminium, copper or bronze.

Simple installation

A contact bolt passes through the Al Elast contact disc, which is arranged between the contact surfaces. During assembly, concentric ring-shaped edges penetrate into the terminal surfaces and create defined, bare metal contact surfaces. Metal yielding phenomena are compensated by the inherent elasticity of the Al Elast contact disc.

Reduced contact corrosion

Al Elast contact discs can connect aluminium and copper busbars to aluminium busbars. In conjunction with PFISTERER P1 contact protection grease, the polyurethane elastomer sealing rings protect the contact points from the negative influences of electrolytes. Thus corrosion is also reduced in Al/Cu connections in indoor and outdoor applications.

Tested reliability

Al Elast contact discs have undergone extensive ageing testing in PFISTERER's test laboratories. Up to 2500 heating cycles were carried out at the contact points with test currents up to 1250 A and temperatures up to 115 °C.

Comparative tests showed that on completion of service life testing, connections with Al Elast contact discs have around 70-80% lower resistance than conventional busbar connections.

The indicated load values apply when Al Elast contact discs are used on flat terminals according to DIN 46206, screwed connections for busbars according to DIN 43673, and similar arrangements.

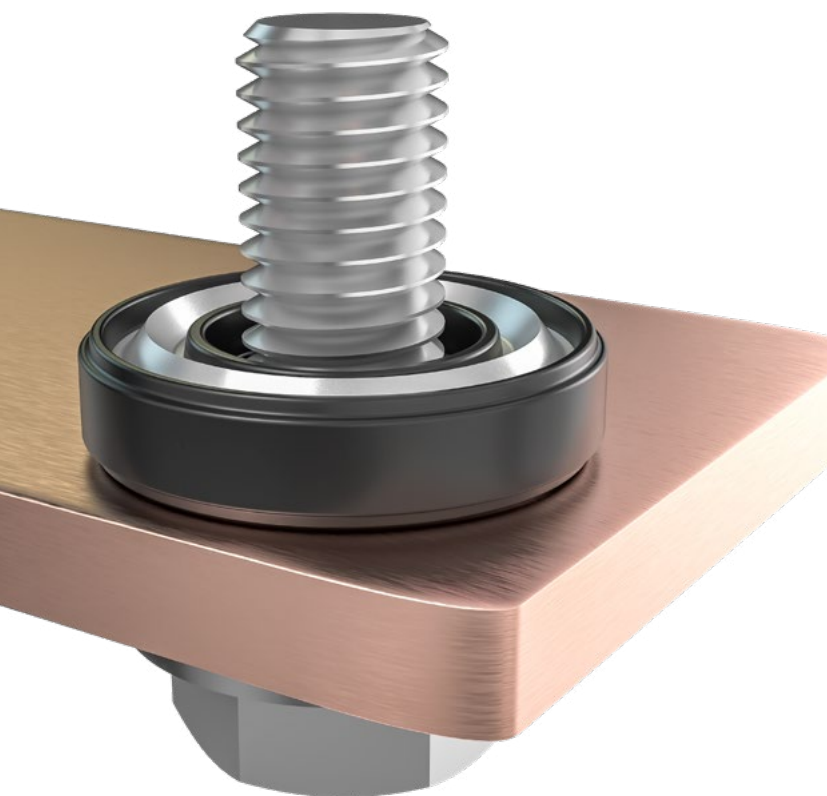

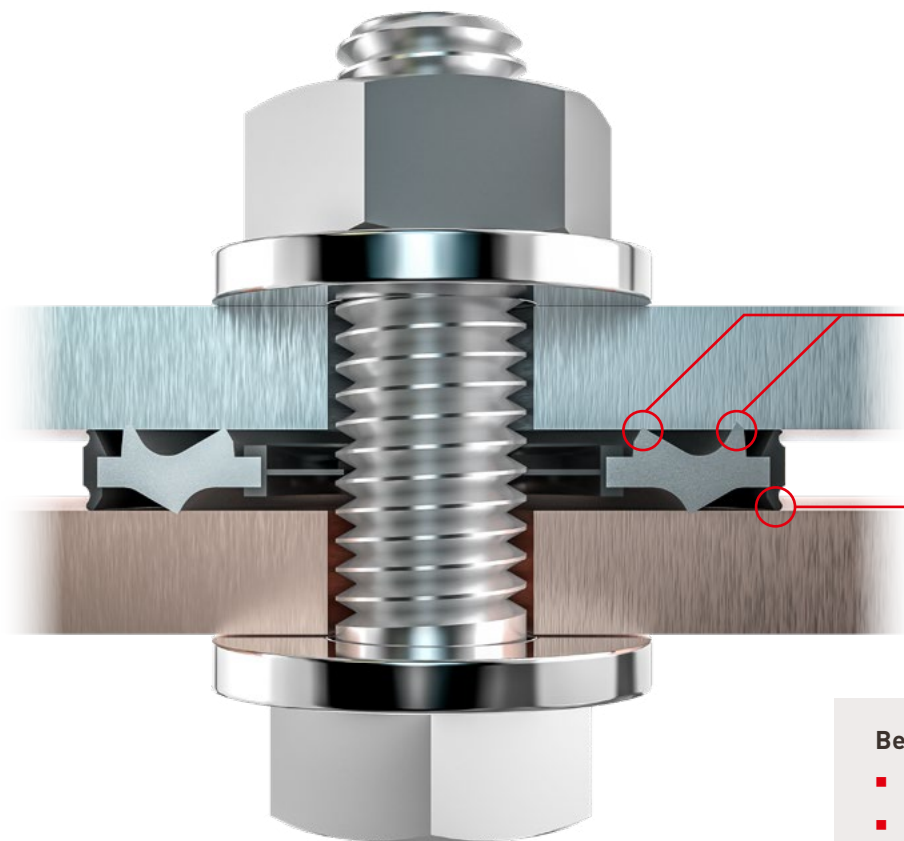

Ring-shaped edge

penetrates the oxide layer and ensures bare metal contact surfaces

Sealing ring

prevents ingress of dirt and liquid

Benefits

- Very good power transmission
- Reliable, ageing-resistant connection
- Connect Al and Cu busbars
- Significantly reduced contact corrosion
- Low risk of installation errors

Basic principles

In high voltage connections, current is only transported at bare metal contact surfaces. These make up a very low proportion of the total overlap surface – in flat terminals only about 3%, based on our experience. The true current density at bare metal contact points is around 30 times higher than the average specific current density.

Therefore – if all other conditions such as mass, contact force and cooling surface are equal – by inserting Al Elast contact discs between the terminal surfaces, which penetrate the flat aluminium surfaces, you can achieve much better stability and higher power carrying capacity with the same true current density.

To prevent a drop in contact force due to yielding phenomena, bolted connections require a certain amount of flexibility. This is ensured by deformation of the disc.

The surfaces of Al Elast contact discs are tinned to prevent the formation of a non-conductive aluminium oxide layer.

Product selection

Bolt size	Rated current I_N [A]	Article no.
Al Elast contact discs		
M8 - M12	350 - 800	332 427 001
M10 - M16	600 - 1250	332 127 127
Sets including washers		
M12	1250	332 110 001*
M16	1250	332 110 004*
P1 contact protection grease (500 ml)		001 531 531

* Contains Al Elast contact disc 332 127 127

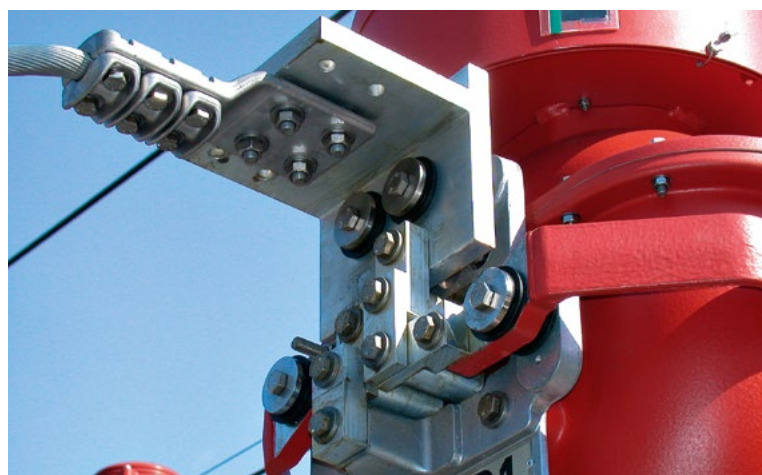

PFISTERER Holding AG

Rosenstraße 44
73650 Winterbach
Germany
Phone: +49 7181 7005 0
Fax: +49 7181 7005 565
info@pfisterer.com
www.pfisterer.com

100
YEARS
PFISTERER
SINCE 1921

In 1921, Karl Pfisterer founded his factory in Stuttgart for special electrical products with the aim of improving the world of power transmission. The PFISTERER Group has pursued this goal of quality and technological leadership for more than 100 years. Today, PFISTERER is one of the world's leading specialists and system suppliers for energy infrastructure – with a complete range of cable accessories, overhead line technology and components along the entire transmission chain from power generation to consumption. With state-of-the-art manufacturing processes and 1,200 employees at 18 international locations, PFISTERER not only connects the power grids of today and tomorrow, but also makes an important contribution to a sustainable and secure energy supply.